

If homeowners were aware of a hole larger than a softball in their front door, they would certainly plug it up. Yet there are thousands of homes in which a 1/8-inch-wide crack exists all the way around a door, and that's the equivalent air loss of a 6-inch-square hole.

Weather-stripping doors can dramatically increase a home's energy efficiency while stopping those cold drafts that leave one feeling chilled.

A simple rule of thumb is if daylight can be observed on a closed outside door, there is leakage that needs to be addressed.

Poorly set hinges cause most door problems. First, tighten all hinge screws. If air is still felt coming in, add weather-stripping.

There are many types of stripping materials, each with its own level of effectiveness, durability and degree of installation difficulty.

The following types are installed on the top and sides of a door, but not on the door-bottom.

Pressure-sensitive, adhesive-backed foam is cheap and the easiest to apply. Available in both rubber and plastic, it seals out the air and also silences slamming. Other kinds of weather-stripping include rolled vinyl with aluminum channel backing, felt, foam rubber with wood backing, spring metal and interlocking metal channels.

The wood or metal hump on the floor along the bottom of the door is called the threshold.

Wooden thresholds can wear down and could need to be replaced.

There are many types of replacement thresholds from which to choose. Many are aluminum and come in standard door widths.

Once the threshold is repaired, install a door sweep to seal the gap between it and the door. Most sweeps are attached to the inside of doors with nails or screws.

In short, weather-stripping doors and replacing worn thresholds can help keep one comfortable in bad weather. These are inexpensive improvements than can be done without having to call a professional.

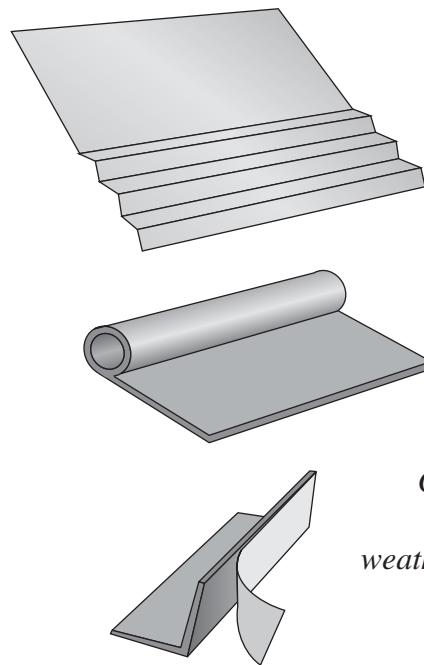

*Common types of weather-stripping*